

Operating Instructions

Quad Unit
WJ-420



Panasonic[®]

Before attempting to connect or operate this product, please read these instructions completely.

CONTENTS

PREFACE	1
FEATURES	1
PRECAUTIONS	1
MAJOR OPERATING CONTROLS AND THEIR FUNCTIONS	2
SYSTEM CONNECTIONS	4
SETUP PROCEDURE	8
RACK MOUNTING	15
SPECIFICATIONS	15
STANDARD ACCESSORIES	15

CAUTION:

Before attempting to connect or operate this product, please read the label on the bottom.



CAUTION

RISK OF ELECTRIC SHOCK
DO NOT OPEN



CAUTION:
TO REDUCE THE RISK OF ELECTRIC SHOCK, DO NOT REMOVE COVER (OR BACK). NO USER SERVICEABLE PARTS INSIDE.
REFER SERVICING TO QUALIFIED SERVICE PERSONNEL.



SA 1965

The lightning flash with arrowhead symbol, within an equilateral triangle, is intended to alert the user to the presence of uninsulated "dangerous voltage" within the product's enclosure that may be of sufficient magnitude to constitute a risk of electric shock to persons.



SA 1966

The exclamation point within an equilateral triangle is intended to alert the user to the presence of important operating and maintenance (servicing) instructions in the literature accompanying the appliance.

For U.S.A.

Warning:
This equipment generates and uses radio frequency energy and if not installed and used properly, i.e., in strict accordance with the instruction manual, may cause harmful interference to radio communications. It has been tested and found to comply with the limits for a Class A computing device pursuant to Subpart J of Part 15 of FCC Rules, which are designed to provide reasonable protection against such interference when operated in a commercial environment.

The serial number of this product may be found on the bottom of the unit.

You should note the serial number of this unit in the space provided and retain this book as a permanent record of your purchase to aid identification in the event of theft.

Model No. _____

Serial No. _____

WARNING:
TO PREVENT FIRE OR SHOCK HAZARD, DO NOT EXPOSE THIS APPLIANCE TO RAIN OR MOISTURE.

PREFACE

The Panasonic WJ-420 Quad Unit is ideal for CCTV applications where multiple surveillance cameras are required. Most 2 : 1 interlace cameras available today, either color or black and white, are compatible with the WJ-420. Up to four cameras may be connected to the system, and if desired, the monitor can be divided into 4 windows for simultaneous display of the four different images.

Simple front panel switch operation allows quick selection between quad and single camera display modes. Additionally, the built-in character generator allows alphanumeric display in each of the four windows of up to 8 characters and symbols for easy identification of camera location.

FEATURES

1. Compatible with Most 2 : 1 Interlace cameras
Advanced digital processing technology allows connection of most 2 : 1 interlace cameras available today without the requirement for synchronization of the four video inputs.
The system may be added to existing security systems and makes possible displays in black and white or full color.
2. Alphanumeric Character Generator
Title insertion, of up to 8 characters in each of the four windows is possible. This promotes easy identification of the separate camera locations.
3. Alarm with Built-in Buzzer
Equipped with an alarm function, this system can be combined with alarm sensors and switches as well as time-lapse VCRs through the alarm output and reset signal connectors.
Upon receiving an alarm signal, a full-sized picture of the site is displayed. By setting the "ALARM TITLE ON" and "TITLE ON" modes from the Setup Menu, "ALARM" and the window title will appear intermittently in the picture.
The Automatic alarm reset time is adjustable from 1 to 30 sec., 1,2,3,4,5 min. or Off.
4. Quad Picture Borderlines
A white borderline can be inserted in the quad pictures by setting "BORDER ON" from the Setup Menu.
5. Two kinds of Video Output Connectors
The Quad system offers two kinds of video output connectors :
 - (a) VIDEO OUT : Quad or full-size single picture can be selected with the front panel switches.
 - (b) VCR OUT : A quad display is always supplied, regardless of the setting of the front panel switches.

Note: Character signals (preset title, "ALARM" or setup menu) can not be output from the VCR OUT Connector.
6. A back-up memory inside maintains preset title character information.

PRECAUTIONS

- Do not block the ventilation slots.
- Do not expose the quad unit to water or moisture.
Do not operate the quad unit if it becomes wet. Do take immediate action if ever the quad unit does become wet. Turn power off and refer servicing to qualified service personnel. Moisture can damage this unit and also create the damage of electric shock.
- Do not attempt to disassemble the quad unit. To prevent electric shock, do not remove screws or cover. There are no user-serviceable parts inside. Refer servicing to qualified service personnel.
- Use this unit under conditions where the temperature is within 14°F - 122°F (-10 °C - +50 °C) and the humidity is below 90%.
- All necessary procedures, with regard to the installation of this product, should be made by qualified service personnel or system installers.

MAJOR OPERATING CONTROLS AND THEIR FUNCTIONS

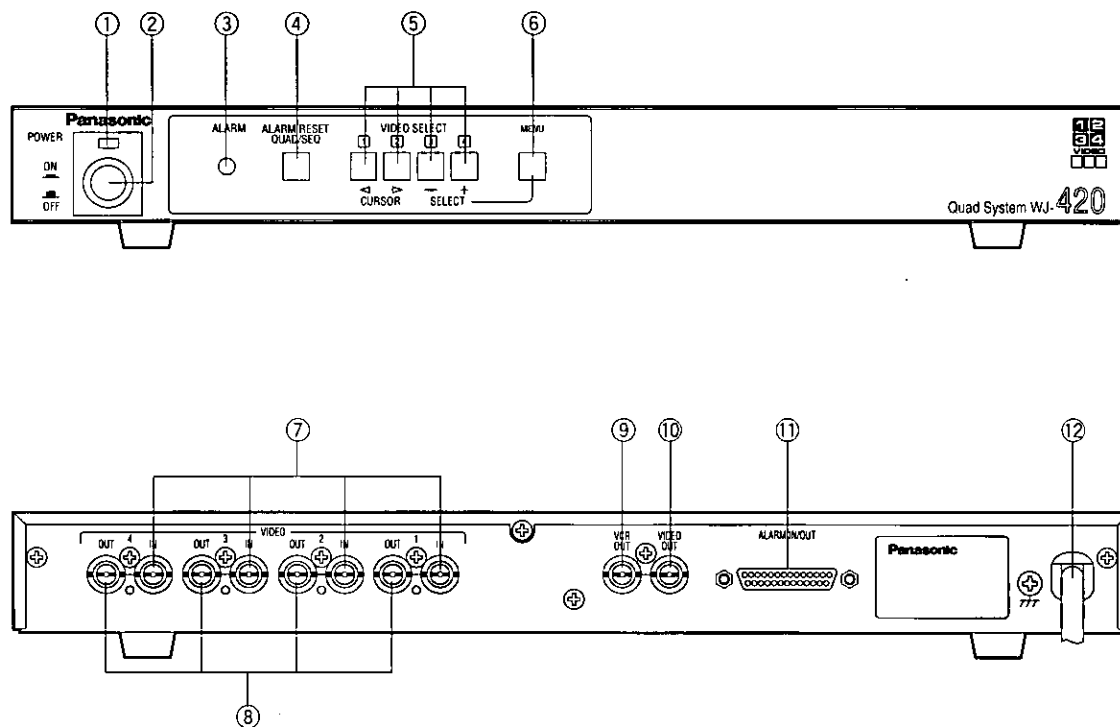

1. Power Indicator

2. POWER ON/OFF Switch

By pressing this switch, the unit turns on and Power Indicator (1) lights up.

3. ALARM Indicator

This indicator blinks when an alarm signal is supplied to the ALARM IN/OUT Connector (11).

4. ALARM RESET, QUAD/SEQ Switch

In the Alarm mode ;

By pressing this switch, the alarm mode is canceled.

The last picture before the alarm mode is displayed.

In the Normal mode ;

By pressing this switch, the unit is in the Quad or Sequential mode which has been previously selected from the Setup Menu.

5. VIDEO SELECT/CURSORS/SELECT Switches (1/2/3/4, </>/-/+)

These switches are used to choose the video signal or move the cursor on the Setup menu.

In the Setup Menu Off mode:

In the 1 (single) picture mode, the selected picture can be displayed.

In the Setup Menu On mode:

These switches are used to move the cursor or select a value or mode.

6. MENU Switch (MENU)

This switch is used to select the Setup Menu On/Off mode.

To display the Setup menu, keep this switch pressed for approx. 2 sec.

7. VIDEO IN Connectors (1/2/3/4)

A composite video signal should be supplied to these connectors.

These connectors terminate automatically.

Notes :

1. If the input signals do not meet with the USA B/W video signal standard, this unit can not be synchronized.
2. If the input signals are very jittery, as in the case of a VCR playback picture, this unit may not be synchronized.

8. VIDEO OUT Connectors (1/2/3/4)

The video input signals connected to the VIDEO IN Connectors (7) are looped through to these connectors.

These connectors become unterminated by connecting a coaxial cable to them.

9. VCR OUT Connector

The video signal (1Vp-p/75 ohms) for the quad picture mode is always provided at this connector.

Note: The character signal is not supplied from this connector.

10. VIDEO OUT Connector (VIDEO OUT)

The video signal selected by the VIDEO SELECT/CURSOR/SELECT Switches (5) or the ALARM RESET, QUAD/SEQ Switch (4) is output from this connector.

11. ALARM IN/OUT Connector

This connector is used for connecting the alarm sensor inputs. Additionally, Alarm Out, Alarm Reset Out and Alarm Recover In are provided here for use with time lapse VCRs. When an alarm signal is triggered, by connecting (shorting) one of the Alarm In pins to ground, the Video Out Connector (8) supplies the alarmed channel's video signal. If both the Alarm Title On mode and the Title On mode are selected from the Setup Menu, the message "ALARM" alternates with the preset title in the video output signal. This connector supplies the Alarm Out signal (open collector circuit) for setting the time lapse VCR to the alarm mode or for sounding a remote chime or buzzer whenever pins 1, 2, 3 or 4 are shorted to ground.

Note :

If an alarm signal is supplied to this unit while it is already in the alarm mode from another alarm input, the later alarm signal has priority.

If 2 or more alarm signals are received simultaneously, the alarm signal from the highest numbered channel has priority. For example, Alarm In 4 would have priority over Alarm In 2.

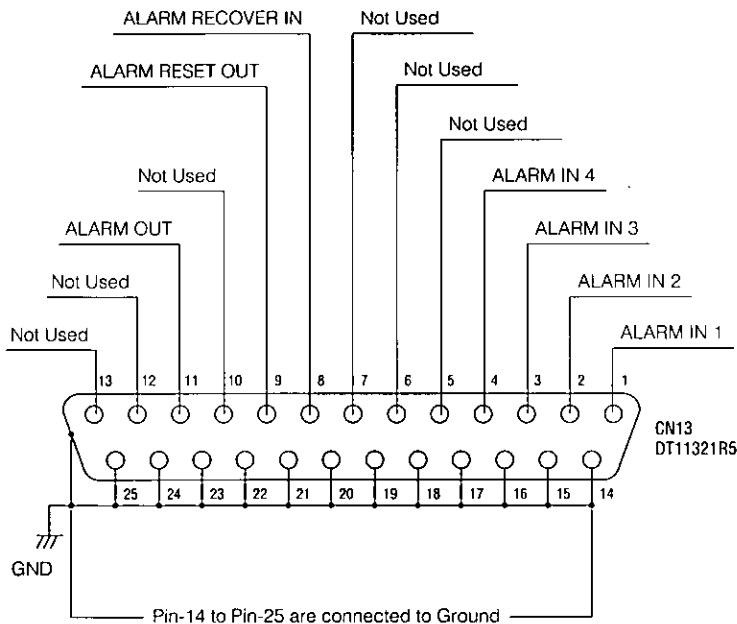

Caution: The input voltage should be DC 24V or less for the ALARM IN.

12. Power Cord

SYSTEM CONNECTIONS

Caution: Keep the Lower Case Switch turned off while making connections.

SYSTEM 1

The input video signals for this unit are not synchronized.

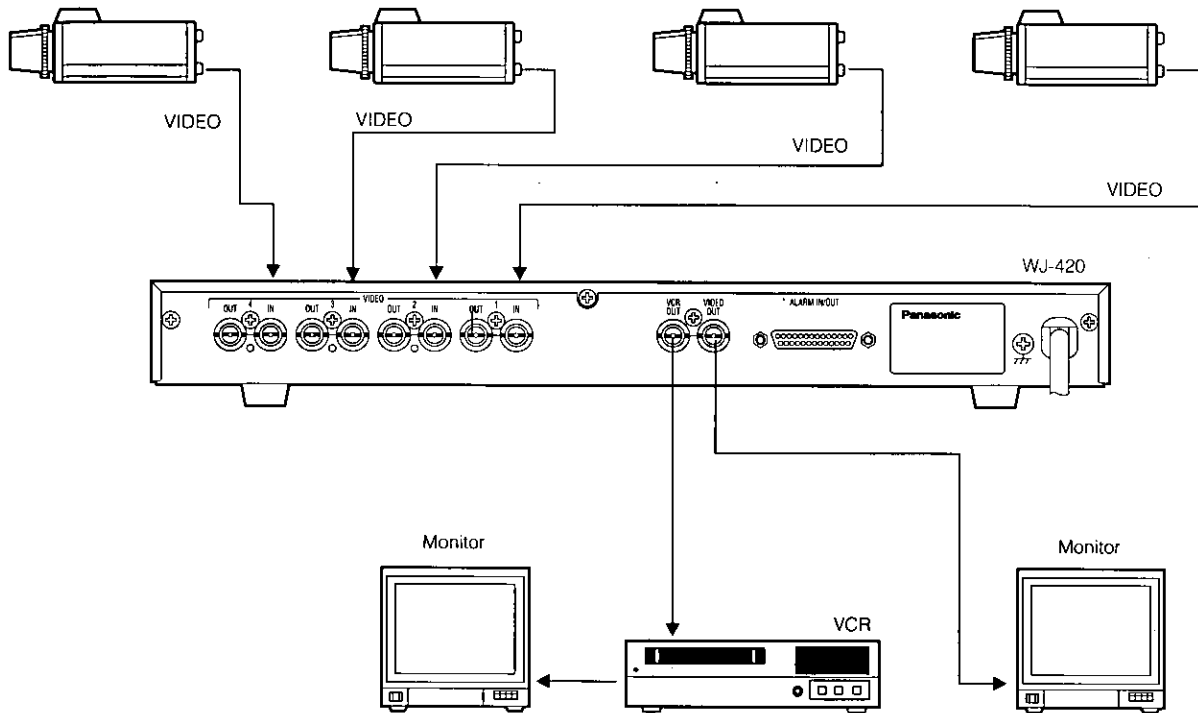

Notes :

- (1) When pressing the ALARM RESET, QUAD/SEQ Switch (4) or the VIDEO SELECT/CURSOR/SELECT Switches (5), the picture on the video monitor may roll briefly at the time of switching.
- (2) The video signal to be recorded by the VCR should be supplied from the VCR OUT Connector (9) of this unit and NOT from the VIDEO OUT (10) Connector of this unit, unless VCR servo control disturbances are allowable when setting the ALARM RESET QUAD/SEQ Switch (4) or the VIDEO SELECT/CURSOR/SELECT Switches (5).

Connections

- Connect the VIDEO IN Connectors (7) of this unit to the Video Output Connectors of the cameras.
- Connect the VCR OUT Connector (9) of this unit to the video input connector of the Time Lapse VCR for recording.
- Connect the VIDEO OUT (10) Connector of this unit to the video input connector of the video monitor.

SYSTEM 2

The input video signals for this unit are synchronized, and synchronization noise or disturbances in the video output signal will not occur when the Quad or Single Picture mode is selected.

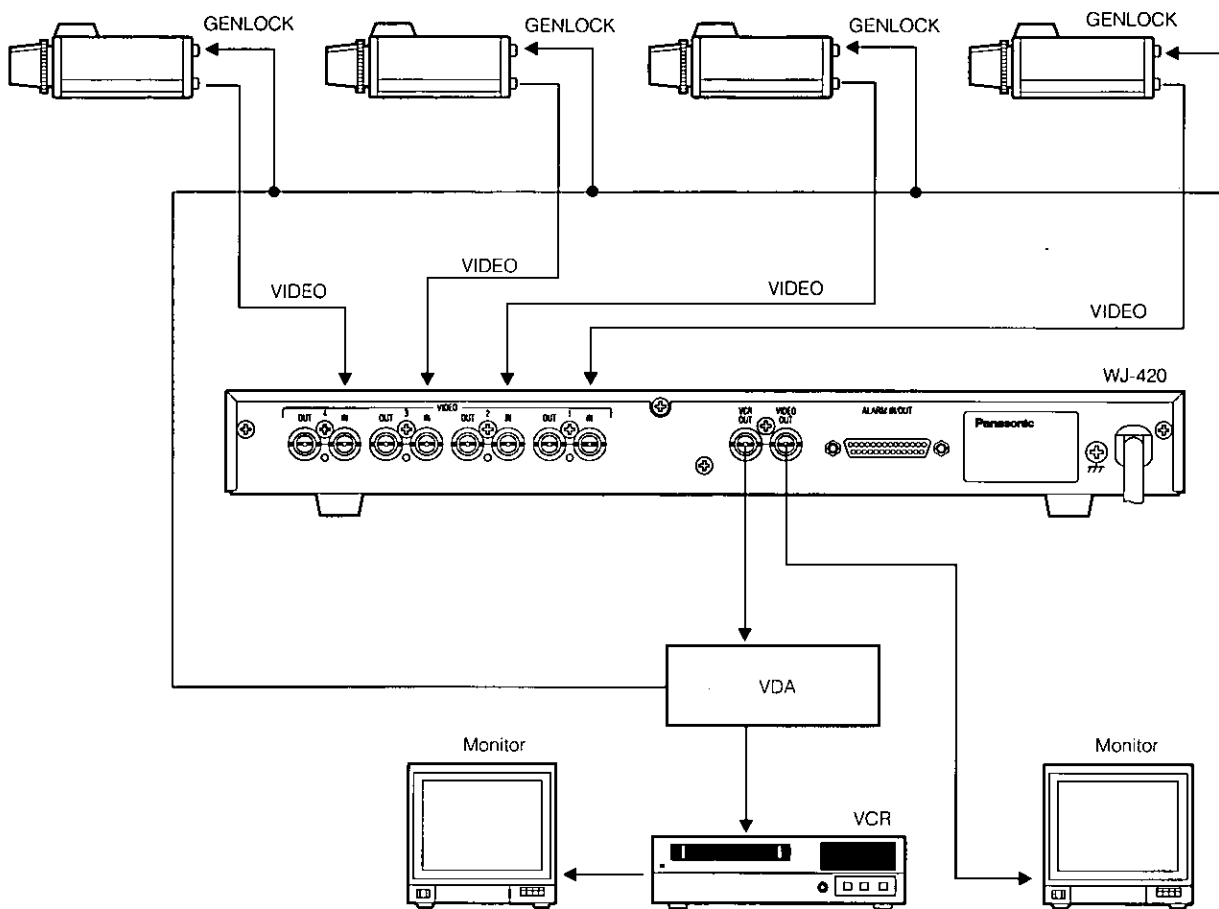

Connections

- Connect the VIDEO IN Connectors (7) of this unit to the video output connectors of the cameras.
- Connect the VCR OUT Connector (9) of this unit to the video input connector of the video distribution amplifier (V.D.A.).
- Connect the output of the video distribution amplifier (V.D.A.) to the video input connector of the Time Lapse VCR and to the gen-lock input connectors of the cameras.
- Connect the VIDEO OUT Connector (10) of this unit to the video input connector of the monitor.

SYSTEM 3

When specified cameras are used with this unit, the WV-PS104B Camera Drive Unit should be used in this system.

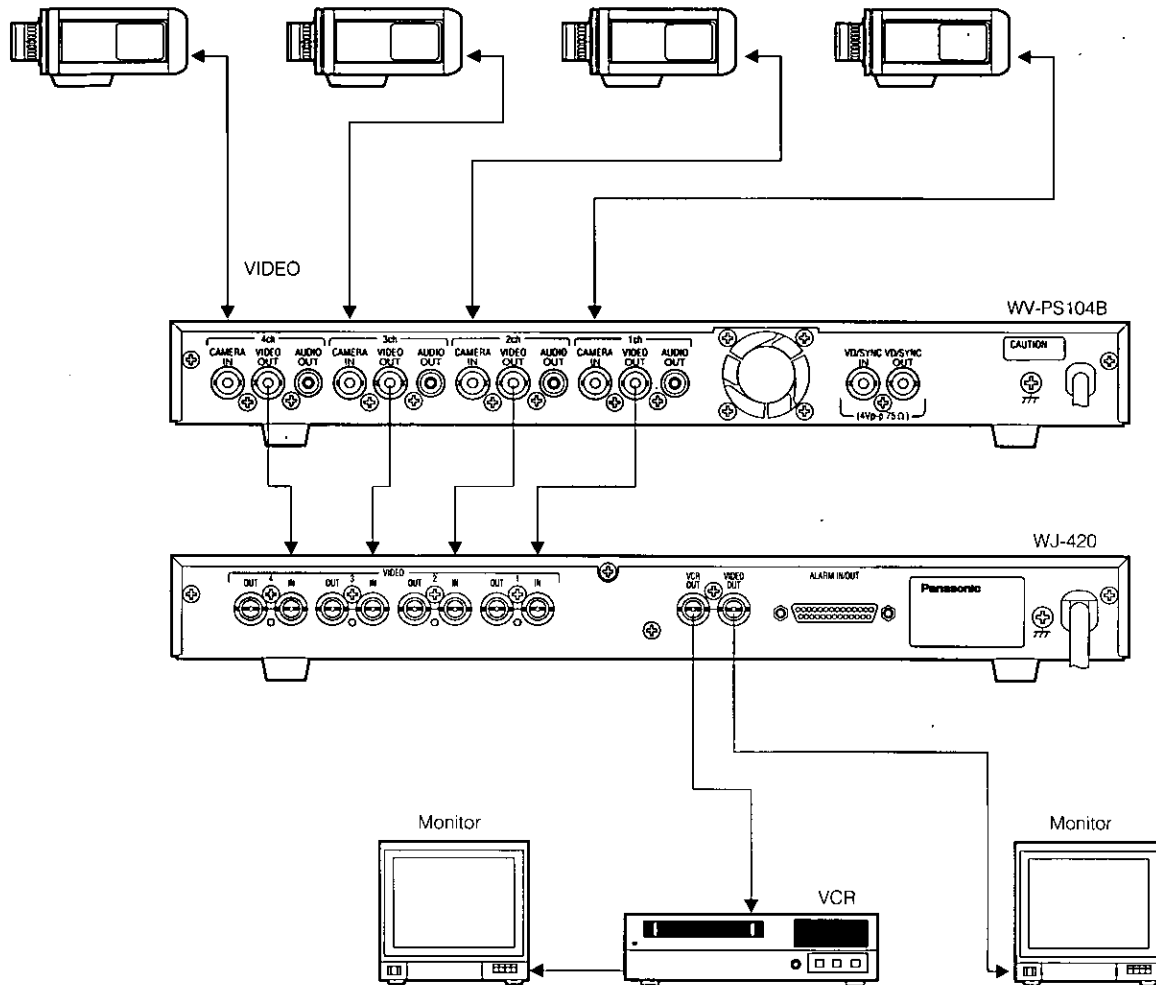

Note: When pressing the ALARM RESET, QUAD/SEQ Switch (4) or the VIDEO SELECT/CURSOR/SELECT Switches (5), the picture on the video monitor may roll briefly at the time of switching.

Connections

- Connect the VIDEO IN Connectors (7) of this unit to the video output connectors of the WV-PS104B Camera Drive Unit.
- Connect the VIDEO OUT Connector (10) of this unit to the video input connector of the monitor.
- Connect the VCR OUT Connector (9) of this unit to the video input connector of the time lapse VCR.
- Connect the video output connectors of the Cameras to the camera input connectors of the WV-PS104B Camera Drive Unit.

SYSTEM 4

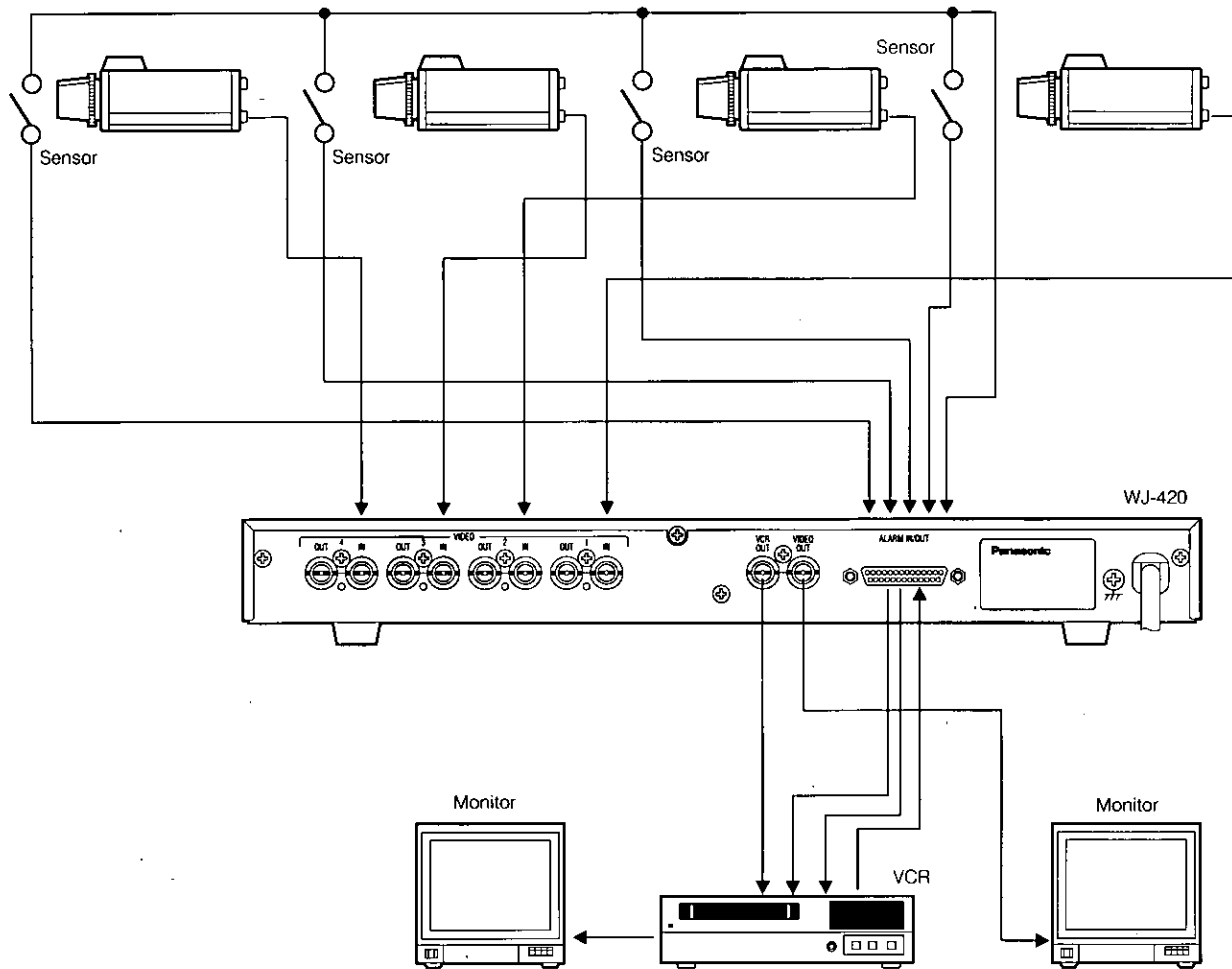

Connections

- Connect the VIDEO IN Connectors (7) of this unit to the video output connectors of the cameras.
- Connect the VCR OUT Connector (9) of this unit to the input connector of the Time Lapse VCR.
- Connect the VIDEO OUT Connector (10) of this unit to the input connector of the monitor.
- Connect the wires of the Alarm Sensors to the alarm input pins of ALARM IN/OUT Connector (11).
- Connect the alarm output pin of ALARM IN/OUT Connector (11) of this unit to the alarm input terminal of the Time Lapse VCR.
- Connect the recover output (alarm reset output) of the Time Lapse VCR and the recover input pin of ALARM IN/OUT Connector (11) of this unit.
- Connect the alarm reset out pin of the ALARM IN/OUT Connector (11) of this unit to the alarm reset in terminal of the Time Lapse VCR.

SETUP PROCEDURE

This quad system utilizes an On-Screen Setup menu for performing setup operations.

1. Entering the Setup Menu

Precaution :

Entering the Setup Menu is not possible while the Alarm Indicator (3) is blinking.
Be sure to reset any alarm prior to setup.

- 1-1. Keep the MENU Switch (6) pressed for approx. 2 sec.
- 1-2. The Setup Menu will be displayed as shown below.

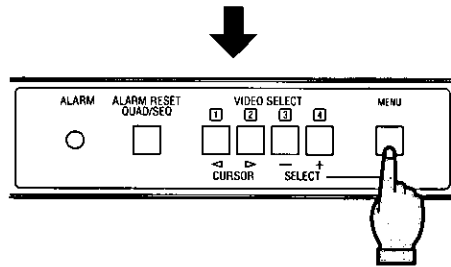
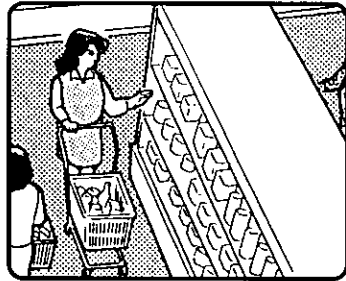

Note: The border line is displayed on the Setup Menu in the BORDER ON mode. The border line is not written in the following setup menu illustrations.

```

** MENU (1/2) **
ALARM BUZZER      2SEC
ALARM OUT         2SEC
ALARM AUTO RESET OFF
ALARM TITLE       ON
TITLE             ON
TITLE EDIT        OFF
TITLE POSI        OFF
BORDER            ON
QUAD/SEQ         QUAD
AUTO SKIP         OFF
    
```

In the Setup Menu On mode ;

The VIDEO SELECT 1/CURSOR (◀) and 2/CURSOR (▶) Switches are used to move the cursor.
The VIDEO SELECT 3/SELECT (–) and 4/SELECT (+) Switches are used for mode selection and for changing values.

Note: The Setup Menu On mode is not available while the ALARM Indicator (3) is blinking. Be sure to reset the Alarm mode to display the Setup Menu.

2. Setup Menu description

2-1. ALARM BUZZER Setting

This sets the time duration of the alarm buzzer by using the VIDEO SELECT 3/SELECT (–) or 4/SELECT (+) Switch as shown below.
This unit sounds the alarm for the preset time when an alarm signal is received.

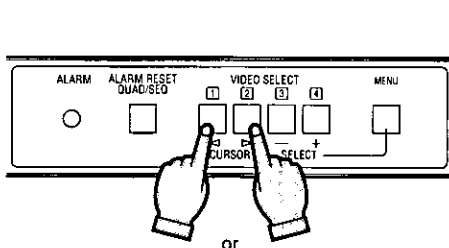

```

** MENU (1/2) **
ALARM BUZZER      [2SEC]
ALARM OUT         2SEC
ALARM AUTO RESET OFF
ALARM TITLE       ON
TITLE             ON
TITLE EDIT        OFF
TITLE POSI        OFF
BORDER            ON
QUAD/SEQ         QUAD
AUTO SKIP         OFF
    
```

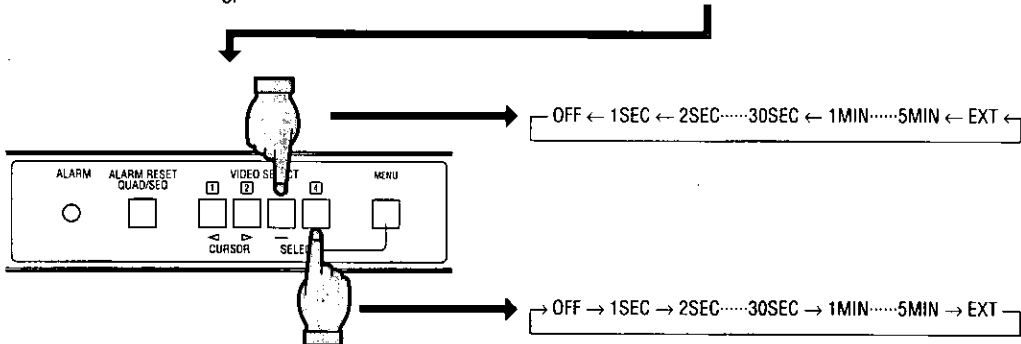

Note: If the ALARM AUTO RESET time is set to a shorter duration than the ALARM BUZZER time, the alarm buzzer will stop sounding with the ALARM AUTO RESET time.

2-2. ALARM OUT Setting

This sets the alarm output signal time duration by using the VIDEO SELECT 3/SELECT (-) or 4/SELECT (+) Switch as shown below.

The alarm signal is output from the Alarm Input/Output Connector (11) for this preset time when an alarm signal is received.

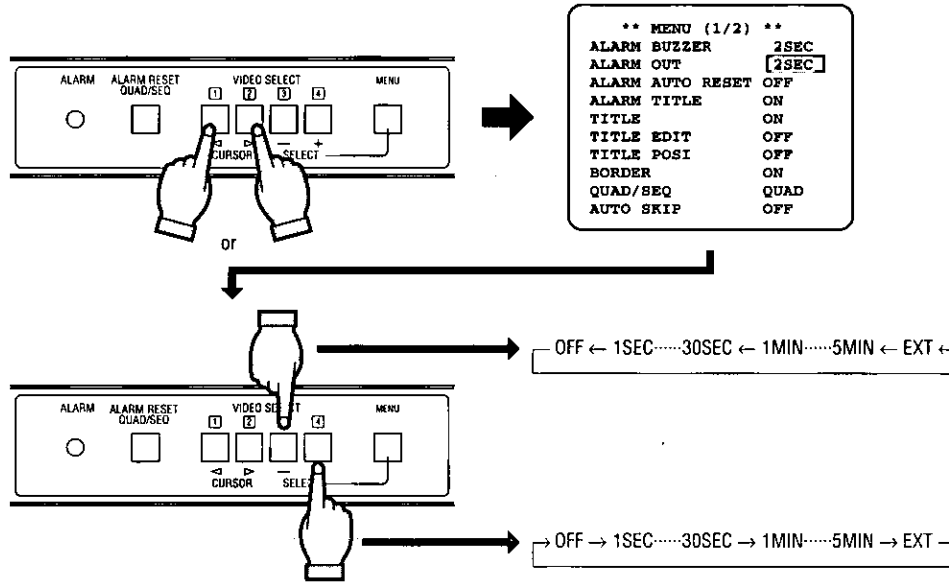

2-3. ALARM AUTO RESET Setting

This sets the automatic recover time from the Alarm mode by using the VIDEO SELECT 3/SELECT (-) or 4/SELECT (+) Switch as shown below.

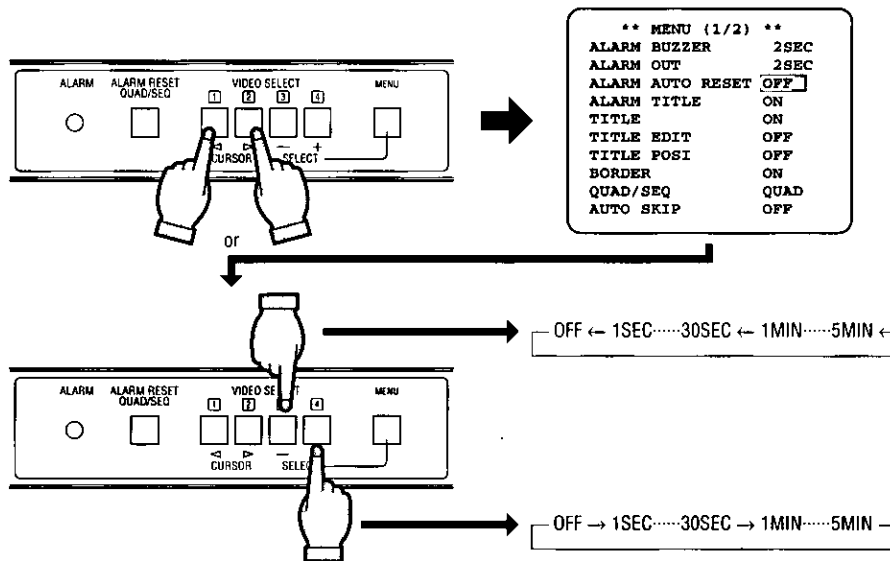

2-4. ALARM TITLE Setting

This selects "ALARM" title display on/off mode by using the VIDEO SELECT 3/SELECT (-) or 4/SELECT (+) Switch.

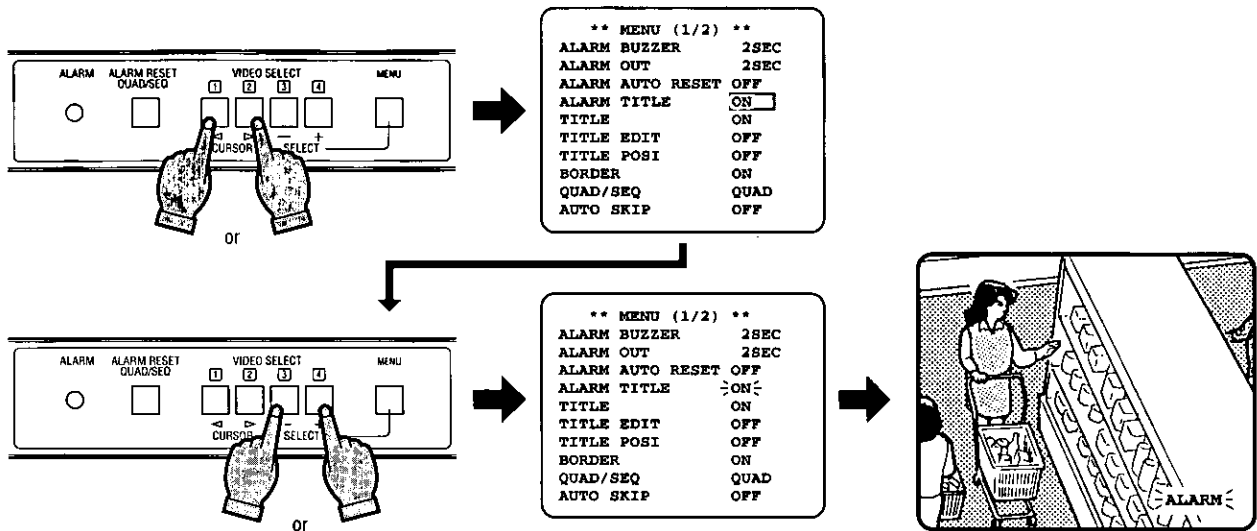

2-5. Title Display On/Off Setting (TITLE)

This selects the display on/off mode of the preset title on the screen by using the VIDEO SELECT, 3/SELECT (-) or 4/SELECT (+) Switch.

The title can be set with the Title Edit Setting from the Setup Menu.

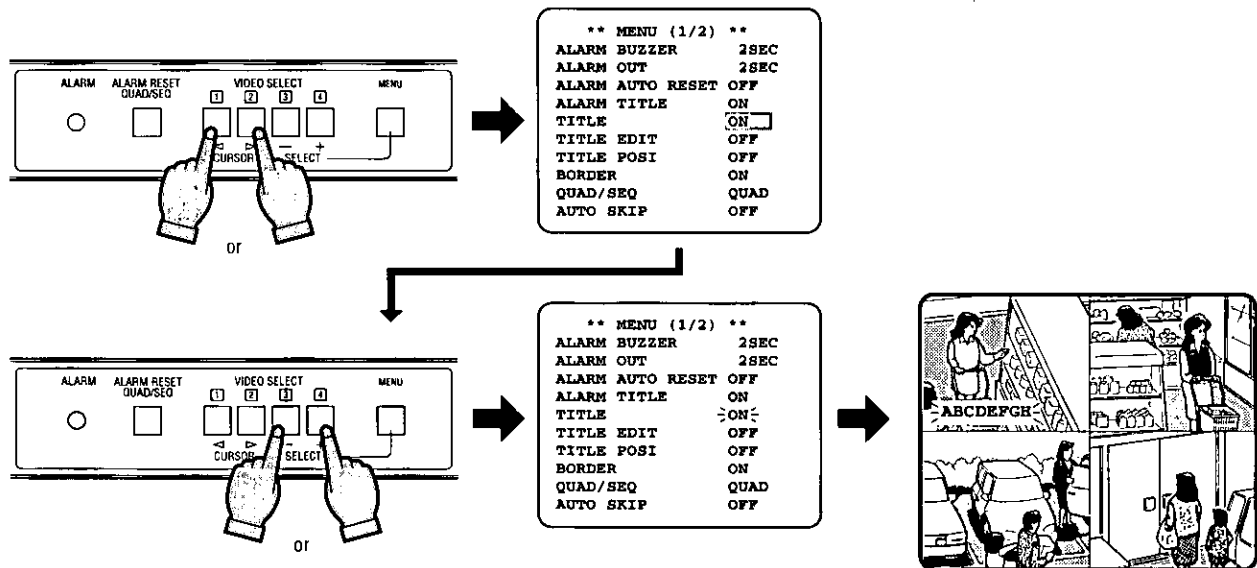

2-6. Title Edit Setting (TITLE EDIT)

This selection is used to edit the title.

The 4 (quad) screen display for title setting appears approx. 1 sec. after selecting TITLE EDIT ON.

To return to the Setup Menu, select EDITING by using the VIDEO SELECT 1/CURSORS (◀) or 2/CURSORS (▶) Switches. (Edit end appears briefly on the screen.)

The Setup Menu is displayed automatically after approx. 1 sec.

To create or edit the title of a channel having the cursor blinking, press the VIDEO SELECT 3/SELECT (-) or 4/SELECT (+) Switch.

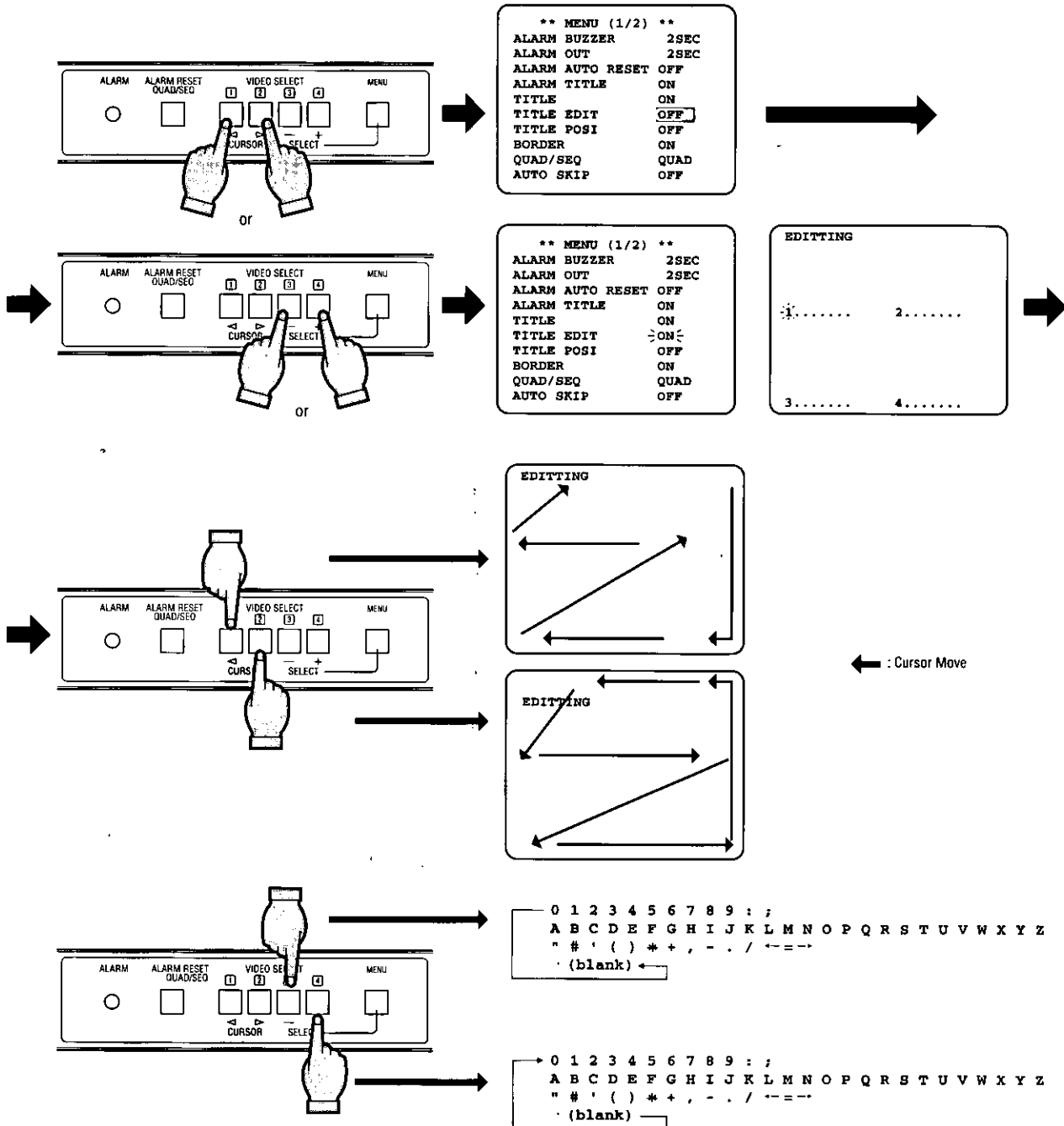

2-7. Title Position Setting (TITLE POSI).

This selects the title position in the TITLE POSI ON mode.

The TITLE POSI is selected by using the VIDEO SELECT 1/CURSOR (◀) or 2/CURSOR (▶) Switch as shown below. By pressing VIDEO SELECT 3/SELECT (+) or 4/SELECT (-), the display position is shifted as shown below.

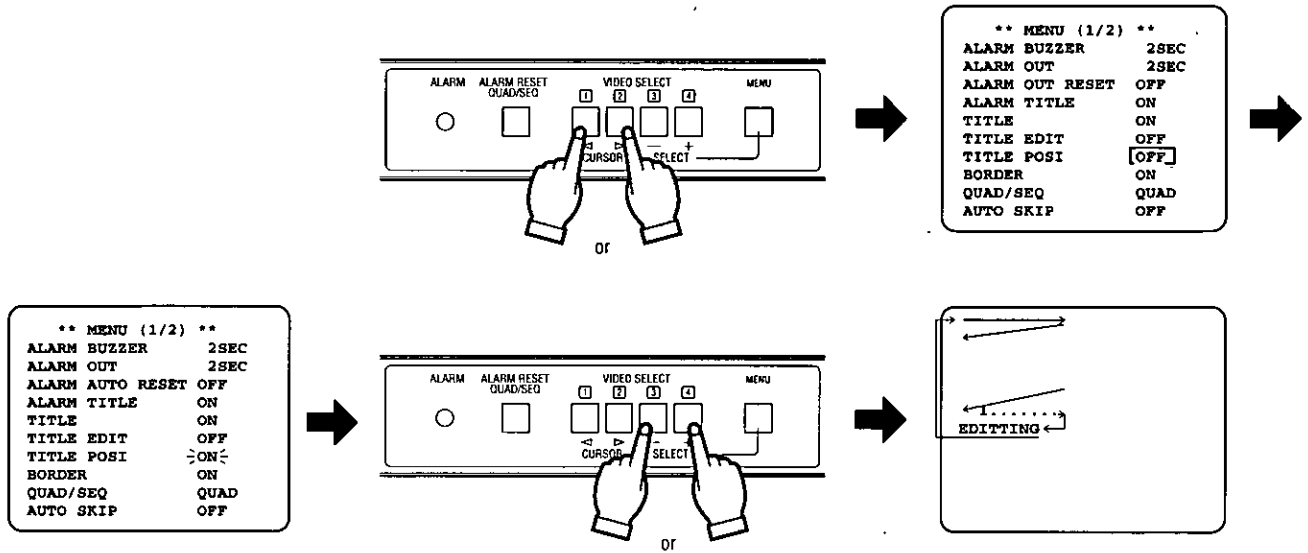

To return to the Setup Menu, select EDITING by using the VIDEO SELECT 1/CURSOR (◀) or 2/CURSOR (▶) Switches.

2-8. Border Line Setting (BORDER)

This selects the display of the border line (white) in the Quad Picture mode.

The BORDER is selected by using the VIDEO SELECT 1/CURSOR (◀) or 2/CURSOR (▶) Switch.

A 4 border line is displayed in the Quad Picture mode by selecting the BORDER ON mode.

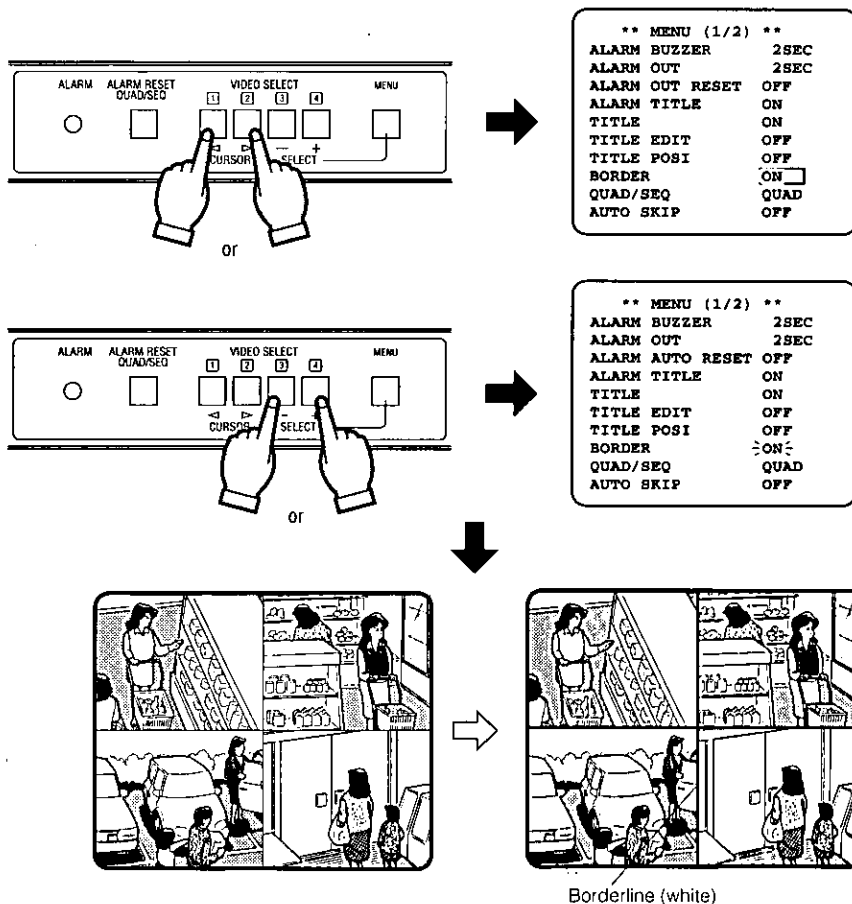

Borderline (white)

2-9. Quad/Sequential Selecting (QUAD/SEQ)

This selects the quad/sequential mode by using the VIDEO SELECT 1/CURSOR (◀) or 2/CURSOR (▶) switch follows:

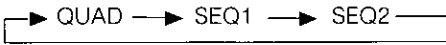

After selecting the desired mode, close the Setup menu and press the ALARM RESET, QUAD/SELECT Switch.

Notes :

1. See section 2-11 for details on SEQ 1 and SEQ 2.
2. The video signal supplied from the VCR OUT connector (9) is always the quad picture mode even if the Sequential mode has been selected.

2-10. Auto Skip Setting (AUTO SKIP)

In the Sequential mode, this selects whether or not to display a channel that has no video signal.

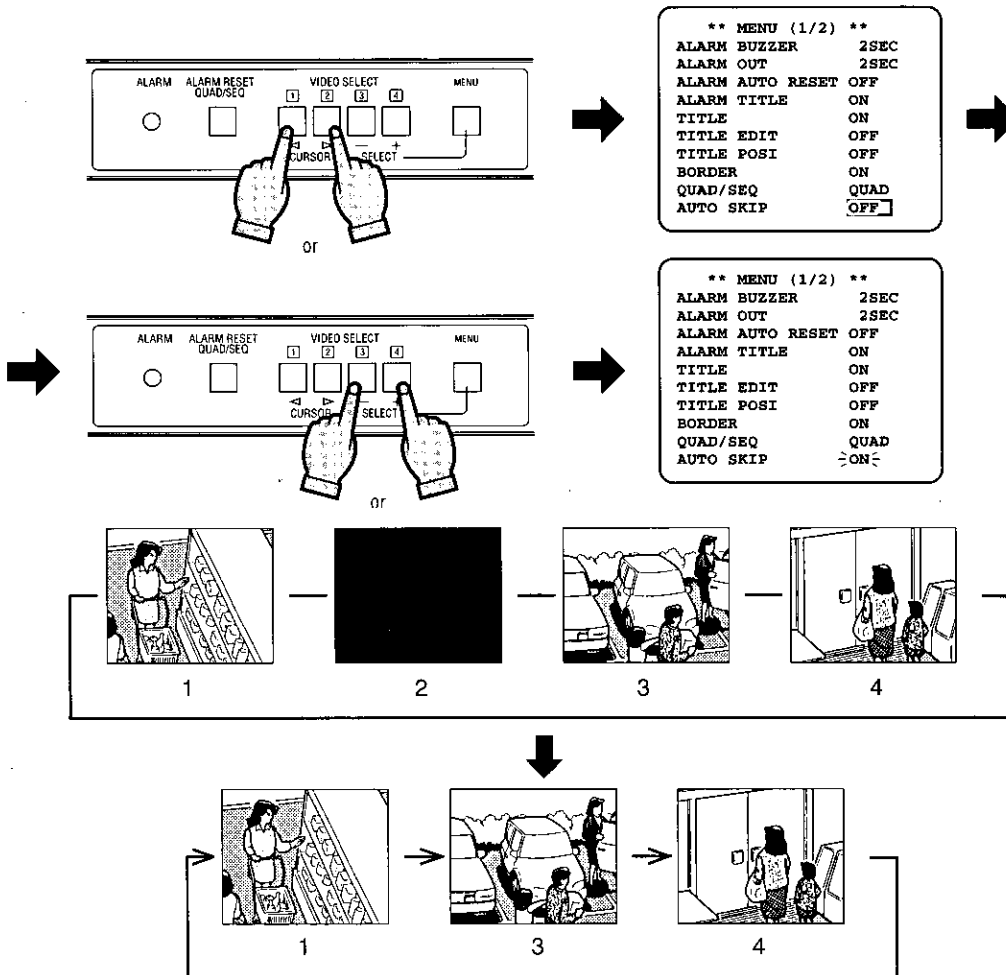

2-11. Sequential 1 and 2 modes Setting (SEQ.1/SEQ.2)

This selection allows for determining the channel preset order and display times for SEQ 1 and SEQ 2 modes. To access the Setup Menu 2/2, which provides for programming channel order and display time, press VIDEO SELECT 1/CURSOR ◀ when the cursor is on the ALARM BUZZER item in the Setup Menu or press VIDEO SELECT 2/CURSOR ▶ when the cursor is on the AUTO SKIP item in the Setup Menu.

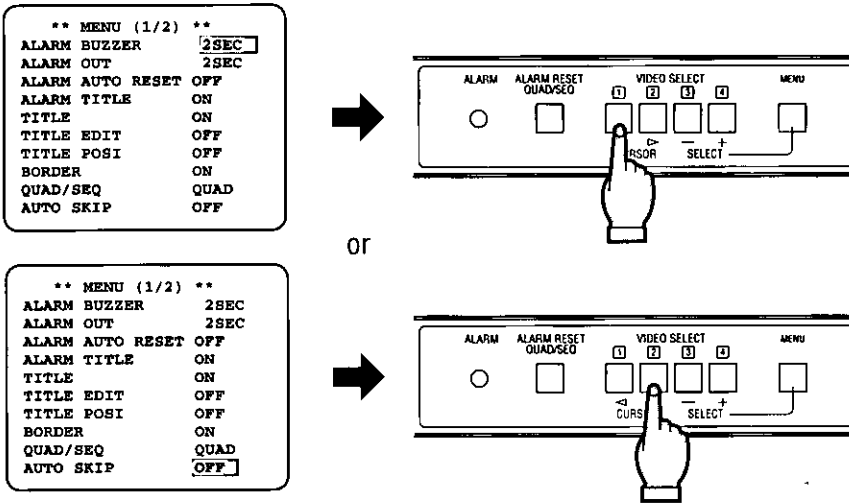

The cursor move in the Setup menu 2/2 is shown in the following.

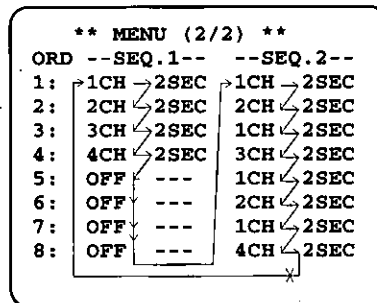

← : Cursor Move

The desired channel order and display time can be selected by using the VIDEO SELECT 3/SELECT (-) or VIDEO SELECT 4/SELECT (+) switches as shown below.

<Channel>

(+) 1CH → 2CH → 3CH → 4CH → OFF

(-) 1CH → OFF → 4CH → 3CH → 2CH

<Display time>

(+) 1SEC → 2SEC → 3SEC 30SEC → Blank

(-) 1SEC → Blank → 30SEC 2SEC → 1SEC

RACK MOUNTING

When this unit is to be mounted in a EIA 19-inch rack, use the Rack Mounting Angle and Rack Mounting Angle Fixing Screws (provided).

1. Turn off the POWER ON/OFF Switch (2) of this unit.
2. Remove four rubber feet from the unit.
3. Attach the Rack Mount Angle on both sides and fix them by using 8 Rack Mount Fixing Screws (provided).
4. Install this unit on the EIA 19-inch rack by using 8 screws (locally purchasing).

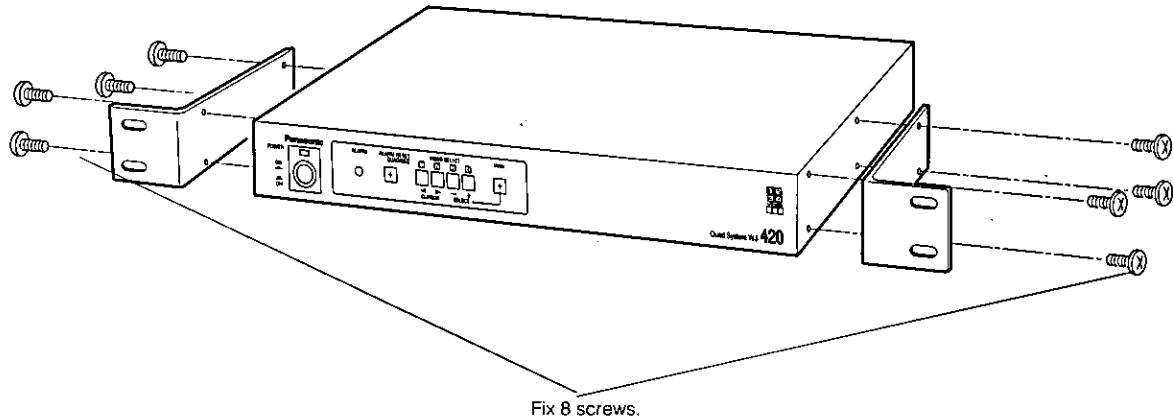

Cautions:

- Do not use this monitor on the place affected by the vibration.
- When the Fan is used to keep the temperature in the rack within 50°C, it should be put apart from the monitor.

SPECIFICATIONS

Video Input :	2:1 interlace, composite 1Vp-p/75 ohms, Auto termination or Loop-through, black and white or color video signal x 4, (Each video signal should be synchronized vertically for vertical interval switching. Does not have to be synchronized in case vertical interval switching is not required.)
Video Output :	Video Output x 1, composite, 1 Vp-p/75 ohms, color or black and white video signal with composite sync and burst signal.
Title :	Up to 8 characters for each window
Alarm Input :	One for each 4 video inputs (Max. DC 12V and a make-contact with the ground)
Alarm Output :	One (Max. DC 24V, 100mA, open collector circuit)
Alarm Time :	Adjustable approx. 1 to 30 seconds, 1,2,3,4,5 min. or EXT
Recover Input :	One (Max. DC 12V and a make-contact for ground)
Auto Reset Time :	Adjustable approx..1 to 30 seconds, 1, 2, 3, 4, 5 min. or OFF
Dimensions :	16-1/2" (W) x 1-3/4" (H) x 13-3/4" (D) 420 (W) x 44 (H) x 350 (D) mm
Weight :	7.9 lbs. (3.6 kg)
Ambient Operating Temperature :	+14°F to +122°F (-10°C to +50°C)
Power Source :	AC 120V, 60Hz

Weight and Dimensions shown above are approximate.
Specifications are subject to change without notice.

STANDARD ACCESSORIES

Rack Mount Angle	1 set
Rack Mount Angle Fixing Screw	8 pcs.

Panasonic

Broadcast & Television Systems Company

Division of Matsushita Electric Corporation of America

CLOSED CIRCUIT VIDEO EQUIPMENT DIVISION

Executive Office: One Panasonic Way, Secaucus, New Jersey 07094

Regional Offices:

Northeast: 43 Hartz Way, Secaucus, NJ 07094 (201) 348-7303

Southeast: 1854 Shackleford Court, Suite 115, Norcross, GA 30003 (404) 717-6835

Midwest: 1707 North Randall Road, Elgin, IL 60123 (708) 468-5200

Southwest: 4500 Amon Carter Blvd., Ft. Worth, TX 76155 (817) 685-1117

Western: 6550 Katella Ave., Cypress, CA 90630 (714) 373-7265

MATSUSHITA ELECTRIC OF CANADA LIMITED

5770 Ambler Drive, Mississauga, Ontario, L4W 2T3 Canada (905) 624-5010

PANASONIC SALES COMPANY

DIVISION OF MATSUSHITA ELECTRIC OF PUERTO RICO, INC.

San Gabriel Industrial Park, 65th Infantry, Ave. KM. 9.5 Carolina, Puerto Rico 00630 (809)750-4300